



Kegelschmiernippel

Ausführung gerade (180°), nach DIN 71412, Form A
 nach DIN gehärtet bzw. ungehärtet auf Kundenwunsch.
 Alte Nr. H 1.

Lubricating Nipples - Hydraulic Type

Straight version (180°), according to DIN 71412, Type A
 case hardened according to DIN or not case-hardened following customer's request.
 Old No. H 1.

Graisseurs à tête cônica

Type droit (180°), selon DIN 71412, Type A,
 Trempé selon DIN ou non trempé sur demande.
 Ancien No. H 1.



type 	Order Nr.		
	Stahl Steel Acier	Messing Brass Laiton	V2A Stainless Steel Inox
M6 x 1,0	5241007	5241101	5241102
1/4"-28 UNF	5241054	5241103	5241104
1/4"-28 NF	5241054		
1/4"-28 SAE	5241054		
M5 x 0,8	1100701	1110701	1120701
M6 x 0,75	1100703	1110703	1120703
M6 x 1,0	1100704	1110704	1120704
1/4"-28 UNF	1100737	1110737	1120737
1/4"-28 NF	1100737	1110737	1120737
1/4"-28 SAE	1100737	1110737	1120737
1/4"-26 BSF	1100744	1110744	1120744
1/4"-WHIT	1100750		
1/4"-BSW	1100750		
M6 x 1,0	5241038		
1/4"-28 UNF	5241055		
1/4"-28 NF	5241055		
1/4"-28 SAE	5241055		
1/4"-26 BSF	5241056		
M6 x 1,0	5241057		
1/4"-28 UNF	5241058		
1/4"-28 NF	5241058		
1/4"-28 SAE	5241058		
1/4"-26 BSF	5241059		
M6 x 1,0	5241060		
1/4"-28 UNF	5241061		
1/4"-28 NF	5241061		
1/4"-28 SAE	5241061		
1/4"-26 BSF	5241062		
M6 x 1,0	5313742		
1/4"-28 UNF	5241080		
1/4"-28 NF	5241080		
1/4"-28 SAE	5241080		
5/16"-24 UNF	5241068		
5/16"-24 NF	5241068		
5/16"-24 SAE	5241068		

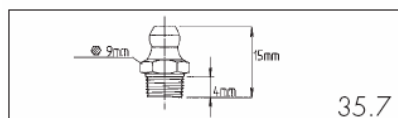
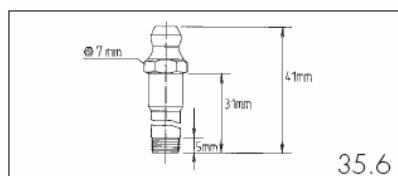
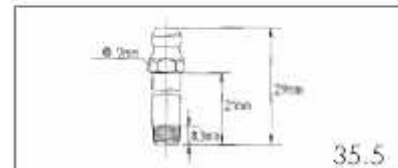
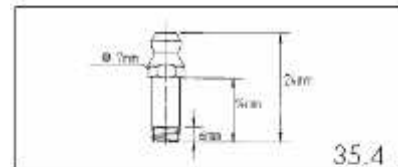
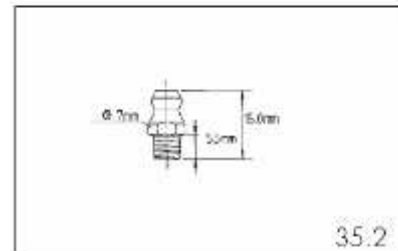
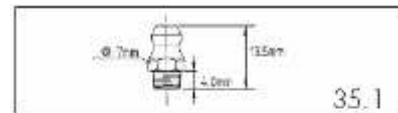

Kegelschmiernippel

Ausführung gerade (180°), nach DIN 71412, Form A
 nach DIN gehärtet bzw. ungehärtet auf Kundenwunsch.
 Alte Nr. H 1.

Lubricating Nipples - Hydraulic Type

Straight version (180°), according to DIN 71412, Type A
 case hardened according to DIN or not case-hardened following customer's request.
 Old No. H 1.

Graisseurs à tête cônica

Type droit (180°), selon DIN 71412, Type A,
 Trempé selon DIN ou non trempé sur demande.
 Ancien No. H 1.



Type	Order Nr.		
	Stahl Steel Acier	Messing Brass Laiton	V2A Stainless Steel Inox
			
M7 x 1,0	1100905		
M8 x 0,75	1100906		
M8 x 1,0	1100907	1110907	1120907
M8 x 1,25	1100908	1110908	1120908
5/16"-24 UNF	1100938	1110938	1120938
5/16"-24 NF	1100938	1110938	1120938
5/16"-24 SAE	1100938	1110938	1120938
5/16"-22 BSF	1100945		
5/16"WHIT	1100951		
5/16"BSW	1100951		
M8 x 1,0	5241009		
M6 x 1,0	1101104		
M10 x 1,0	1101109	1111109	1121109
M10 x 1,25	1101110		
M10 x 1,5	1101111		
3/8"-24 UNF	1101139	1111139	1121139
3/8"-24 NF	1101139	1111139	1121139
3/8"-24 SAE	1101139	1111139	1121139
3/8"-20 BSF	1101146		
3/8"WHIT	1101152		
3/8"BSW	1101152		
R1/8"	1101156	1111156	1121156
1/8"-28 BSP	1101156	1111156	1121156
1/8"-27 NPT	1101167	1111167	
1/8"-27 PTF	1101167	1111167	
M10 x 1,0	5241074		
1/8"-27 NPT	5241024	5241105	5241106
1/8"-27 PTF	5241024	5241105	5241106
1/8"-27 NPT	5241075		
1/8"-27 PTF	5241075		

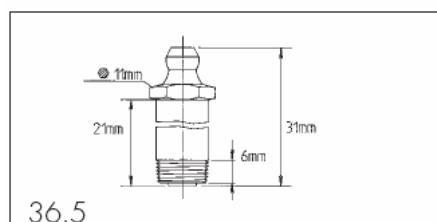
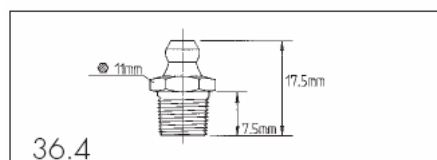
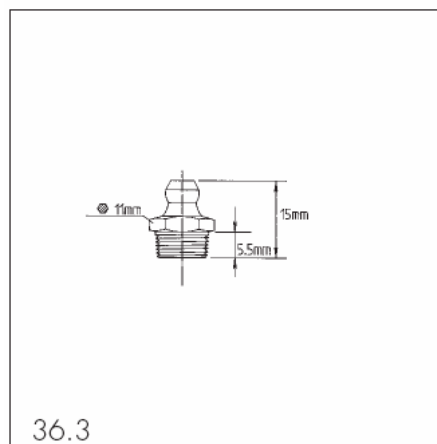
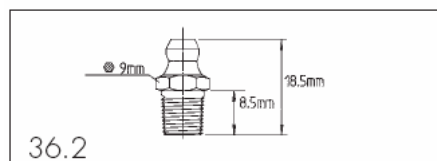
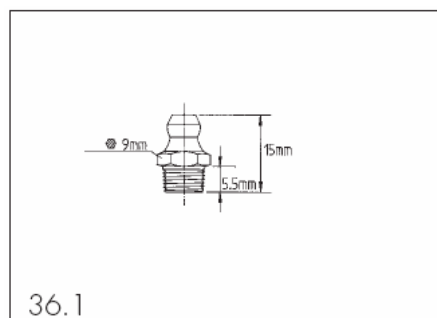



Kegelschmiernippel

Ausführung gerade (180°), nach DIN 71412, Form A
 nach DIN gehärtet bzw. ungehärtet auf Kundenwunsch.
 Alte Nr. H 1.

Lubricating Nipples - Hydraulic Type

Straight version (180°), according to DIN 71412, Type A
 case hardened according to DIN or not case-hardened following customer's request.
 Old No. H 1.

Graisseurs à tête cônica

Type droit (180°), selon DIN 71412, Type A,
 Trempé selon DIN ou non trempé sur demande.
 Ancien No. H 1.



Type	Order Nr.		
	Stahl Steel Acier	Messing Brass Laiton	V2A Stainless Steel Inox
			
1/8"-27 NPT	5241076		
1/8"-27 PTF	5241076		
R1/8"	5241070		
1/8"-28 BSP	5241070		
1/8"-27 NPT	5241077		
1/8"-27 PTF	5241077		
R1/4"	1101457	1111457	1121457
1/4"-19 BSP	1101457		
1/4"-18 NPT	1101468		
1/4"-18 PTF	1101468		
M12 x 1,0	1101412		
M12 x 1,25	1101413		
M12 x 1,5	1101414	1111414	1121414
M12 x 1,75	1101415		
R1/4"	5241071		
1/4"-19 BSP	5241071		
1/4"-18 NPT	5241072		
1/4"-18 PTF	5241072		
R3/8"	1101758		
3/8"-19 BSP	1101758		
M16 x 1,5	1101719		
3/8"-18 NPT	1101769		
3/8"-18 PTF	1101769		

