

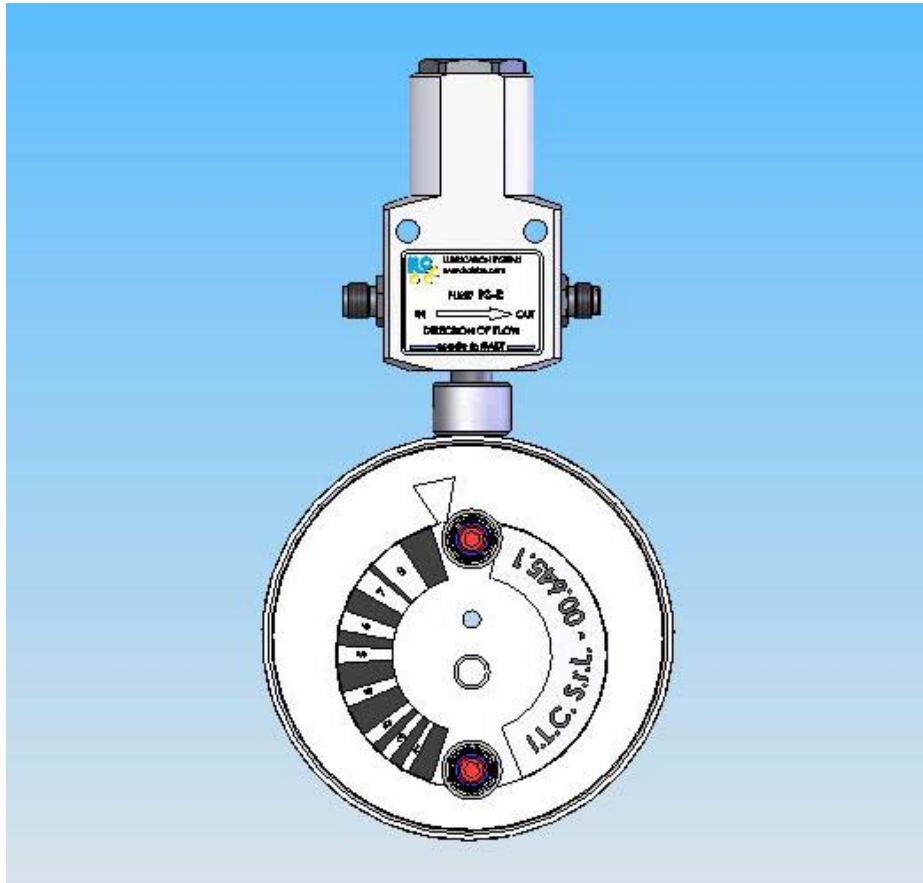

LUBRIFICAZIONE AUTOMATICA DELLE CATENE AUTOMATIC CHAINS LUBRICATION

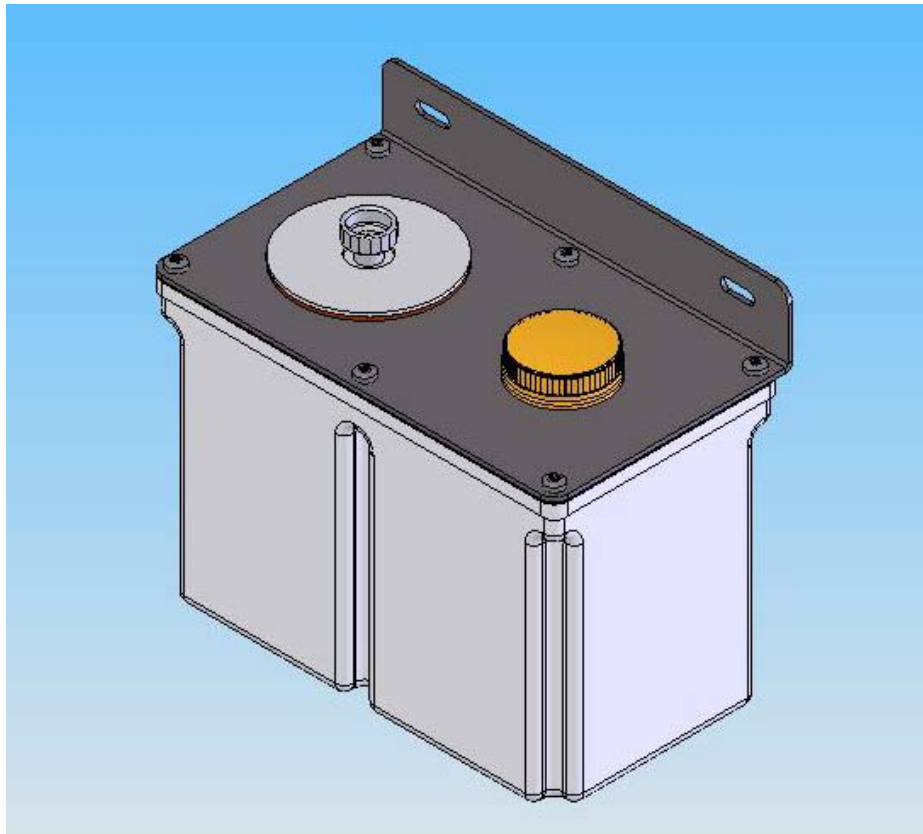

BVBA POMAC-LUB-SERVICES SPRL Pottestraat 23 B-8970 Poperinge
Tel. 057/33 48 36 – Fax 057/33 61 27 info@pomac.be – internet: www.pomac.be



LUBRIFICAZIONE AUTOMATICA DELLE CATENE AUTOMATIC CHAINS LUBRICATION

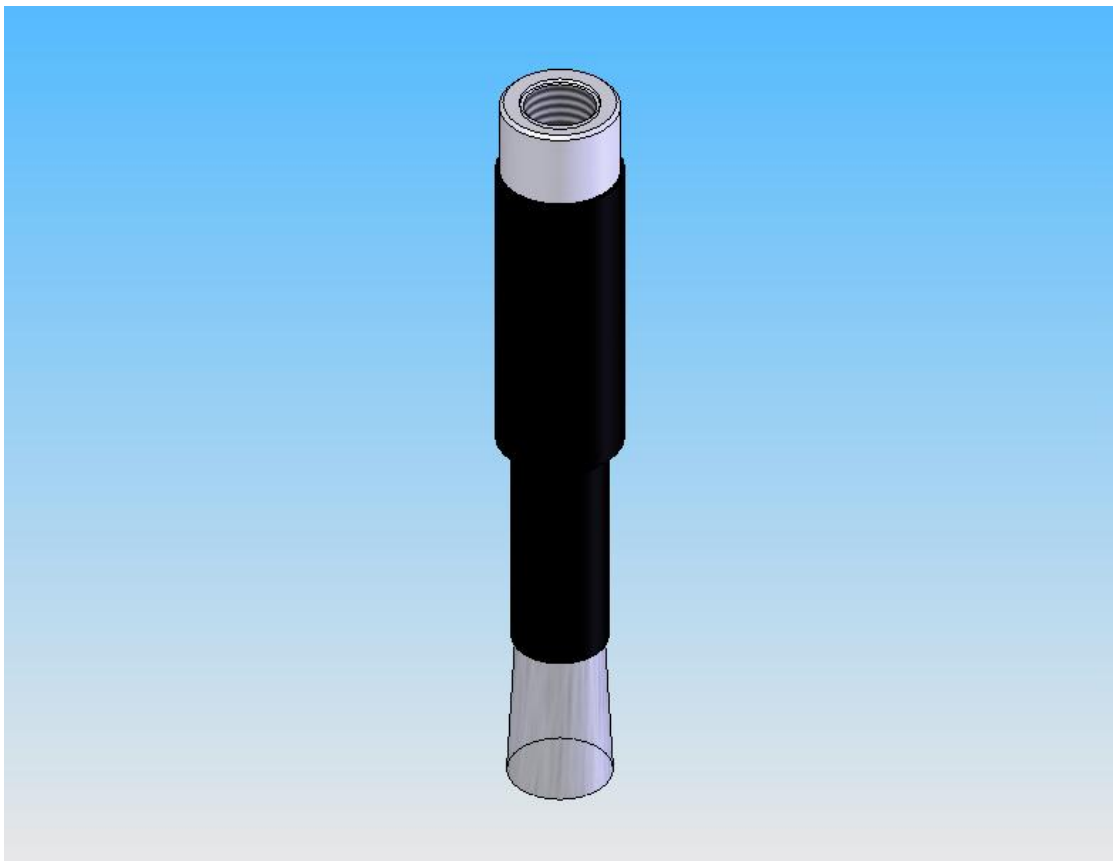
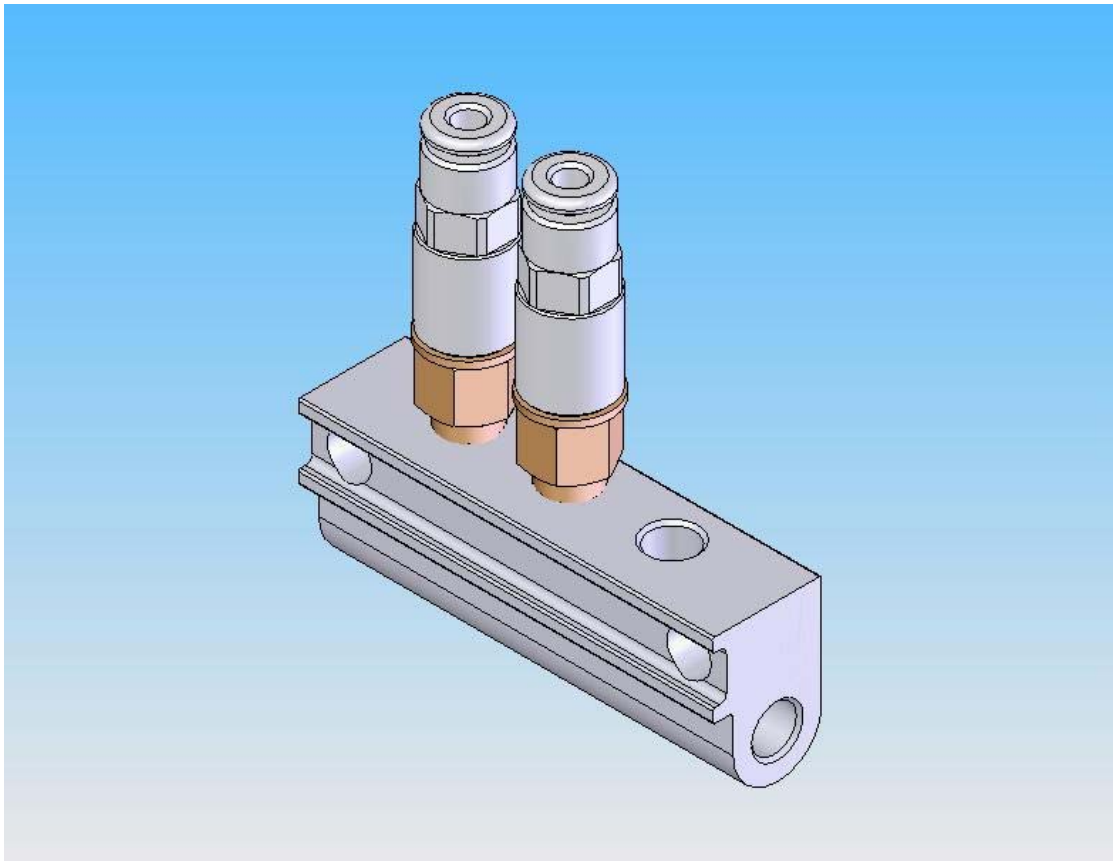

BVBA POMAC-LUB-SERVICES SPRL Pottestraat 23 B-8970 Poperinge
Tel. 057/33 48 36 – Fax 057/33 61 27 info@pomac.be – internet: www.pomac.be



LUBRIFICAZIONE AUTOMATICA DELLE CATENE AUTOMATIC CHAINS LUBRICATION

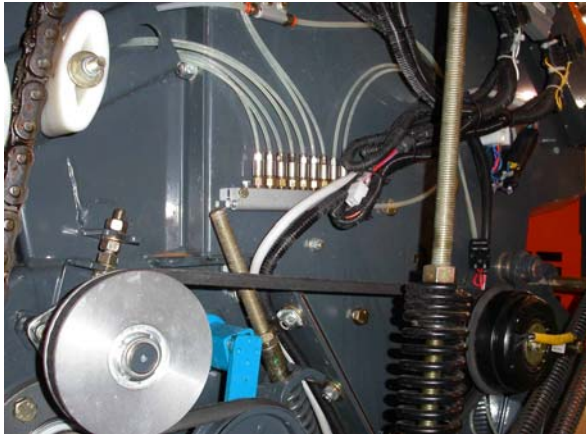

BVBA POMAC-LUB-SERVICES SPRL Pottestraat 23 B-8970 Poperinge
Tel. 057/33 48 36 – Fax 057/33 61 27 info@pomac.be – internet: www.pomac.be



LUBRIFICAZIONE AUTOMATICA DELLE CATENE AUTOMATIC CHAINS LUBRICATION

LUBRIFICAZIONE AUTOMATICA DELLE CATENE PER LE
MACCHINE AGRICOLE

*AUTOMATIC CHAINS LUBRICATION PURPOSE DESIGNED FOR
AGRICULTURAL EQUIPMENT*

SISTEMA AZIONATO PER MEZZO DI UNA CAMMA

THE SYSTEM IS OPERATED BY MEANS OF A CAM

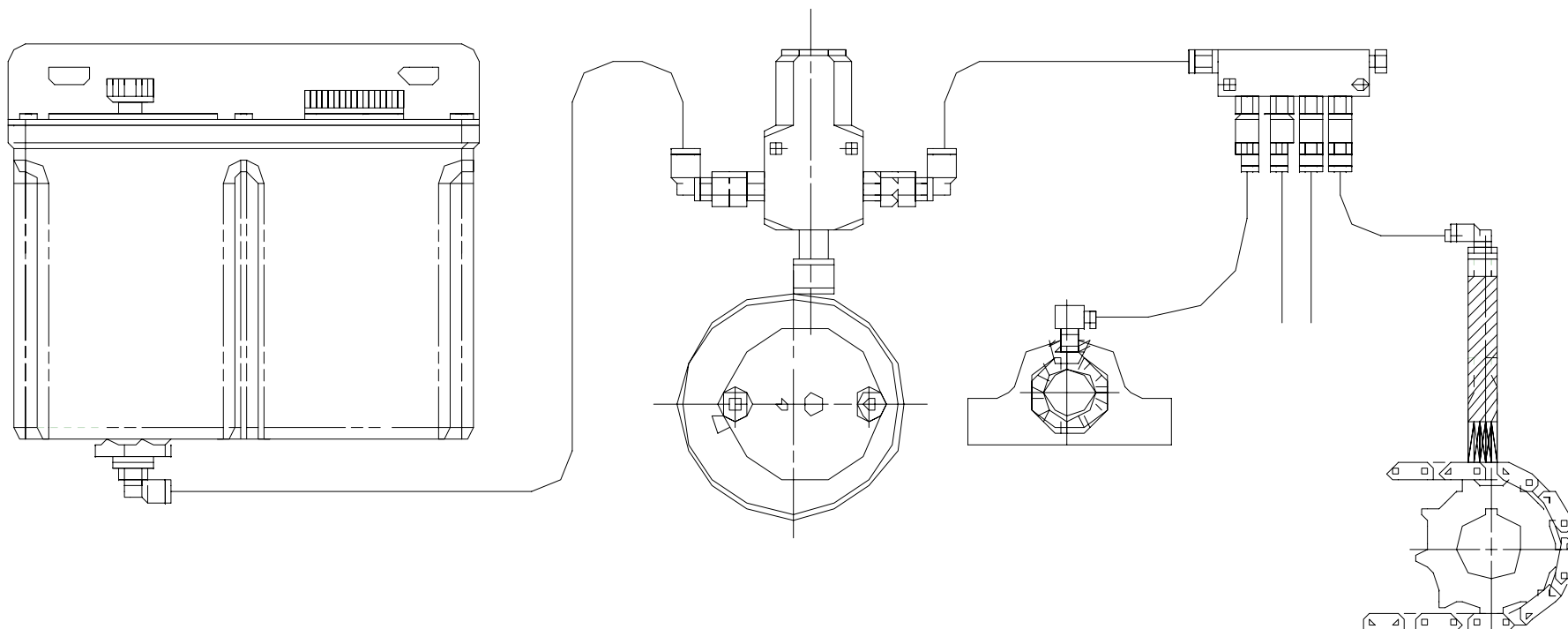

BVBA POMAC-LUB-SERVICES SPRL Pottestraat 23 B-8970 Poperinge
Tel. 057/33 48 36 – Fax 057/33 61 27 info@pomac.be – internet:www.pomac.be



LUBRIFICAZIONE AUTOMATICA DELLE CATENE AUTOMATIC CHAINS LUBRICATION

IL SISTEMA E' STATO STUDIATO PER ESERE APPLICATO PRINCIPALMENTE NELLE MACCHINE AGRICOLE COME ROTOPRESSE PER BALLE TONDE O QUADRE, RACCOGLITRICI E PER TUTTE LE MACCHINE CHE HANNO UN PERSISTENTE PROBLEMA DI LUBRIFICAZIONE

LOW COST CONTROLLED OILING FOR ROUND AND SQUARE BALERS, HEADERS, TURF EQUIPMENT AND ANY APPLICATION WITH PERSISTENT LUBRICATION PROBLEMS

PROTEGGE LE PARTI CRITICHE IN MOVIMENTO

PROTECT CRITICAL MOVING PARTS

- FORNISCE DELLE CORRETTE QUANTITA' DI OLIO AI PUNTI
- UN UNICO SISTEMA PER LE CATENE E I CUSCINETTI
- PROTEGGE OGNI CUSCINETTO, E LE SUE TENUTE PER MEZZO DI UN FLUSSO D'OLIO CONTROLLATO E COSTANTE
- AIUTA A MANTENERE LE CATENE OLiate DOVE SI RACCOGLIE LA POLVERE E SI FORMA UNA PASTA ABRASIVA
- LA POMPA E' COMANDATA DAL CICLO DELLA MACCHINA
- LA PORTATA DEL LUBRIFICANTE PUO' ESSERE FACILMENTE REGOLATA PER ADATTARSI ALLE VARIE RICHIESTE
- SONO DISPONIBILI KIT PREASSEMBLATI PER LE APPLICAZIONI PIU' COMUNI

- *PROVIDES METERED LUBRICATION TO EACH POINT ACCORDING TO ITS NEED*
- *A SINGLE SYSTEM OILS BOTH BEARINGS AND CHAINS IN ANY COMBINATION*
- *PROTECTS EACH BEARING AND ITS SEAL BY CONSTANT, CONTROLLED FLUSHING*
- *HELPS KEEP CHAINS OILED ABOVE LEVEL WHERE DUST COLLECTS AND GRINDING PASTE FORMS*
- *SIMPLE MECHANICAL PUMP DRIVE OPERATES FROM MACHINE CYCLE*
- *OVERALL OUTPUT ADJUST EASILY TO SUIT VARYING OPERATION CONDITIONS*
- *PRE-ASSEMBLED KITS AVAILABLE FOR COMMON APPLICATIONS*

IL PRINCIPIO

IL SISTEMA E' PROGETTATO PER FORNIRE COSTANTEMENTE UNA PICCOLA QUANTITA' DI LUBRIFICANTE DURANTE LE ORE LAVORATIVE

THE PRINCIPLE

THE KIT IS DESIGNED TO FEED SMALL QUANTITIES OF LUBRICANT CONSTANTLY TO CHAINS THROUGHOUT THE WORKING DAY

LUBRIFICANTE

USARE SOLO I LUBRIFICANTI RACCOMANDATI. L'OLIO CORETTO E' IL SAE30 SPECIFICHE APICC/CD. EVITARE GLI OLI IDRAULICI UNIVERSALI O MULTISCOPO. NON USARE OLII CON ADDITIVI EP

LUBRICANT

ONLY USE RECOMMENDED LUBRICANTS. CORRECT OIL: SAE30 TO APICC/CD SPECIFICATION. AVOID ALL UNIVERSAL AND MULTIPURPOSE OILS. USE NO OILS WITH CONCENTRATED EP PACKAGES

SISTEMA

LA POMPA PS-R ASPIRA L'OLIO DAL SERBATOIO E LO DISTRIBUISCE ALLE VALVOLE DOSATRICI. OGNI CATENA RICEVE DELLE ACCURATE QUANTITA' DI OLIO.

SYSTEM

OIL IS GRAVITY FED TO THE MECHANICALLY OPERATED PS-R PUMP. PRESSURE OIL IS PROVIDED TO INDIVIDUAL METEING VALVES AROUND THE MACHINE; EACH SUPPLYING ACCURATE QUANTITIES OF LUBRICANT TO A CHOSEN CHAIN.

BVBA POMAC-LUB-SERVICES SPRL Pottestraat 23 B-8970 Poperinge
Tel. 057/33 48 36 – Fax 057/33 61 27 info@pomac.be – internet: www.pomac.be



LUBRIFICAZIONE AUTOMATICA DELLE CATENE AUTOMATIC CHAINS LUBRICATION

DESCRIZIONE COMPONENTI

1. SERBATOIO 3 L
2. POMPA A PISTONE PS-R
3. ECCENTRICO
4. DISTRIBUTORI
5. VALVOLE DOSATRICI
6. SPAZZOLE

EQUIPMENT DESCRIPTION

1. RESERVOIR 3 L
2. PISTON PUMP PS-R
3. CAM
4. MANIFOLDS
5. METERING UNITS
6. BRUSHES

SERBATOIO SEMITRASPARENTE 3 L COMPLETO DI FILTRO DI ASPIRAZIONE (50 µ). CODICE 00.646.7

3 L PLASTIC RESERVOIR COMPLETE WITH SUCTION STRAINER (50 µ). CODE 00.646.7

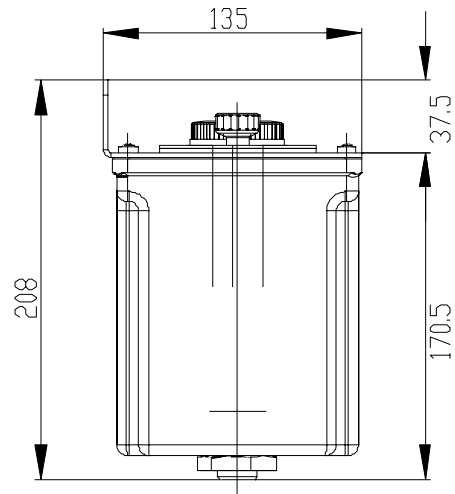
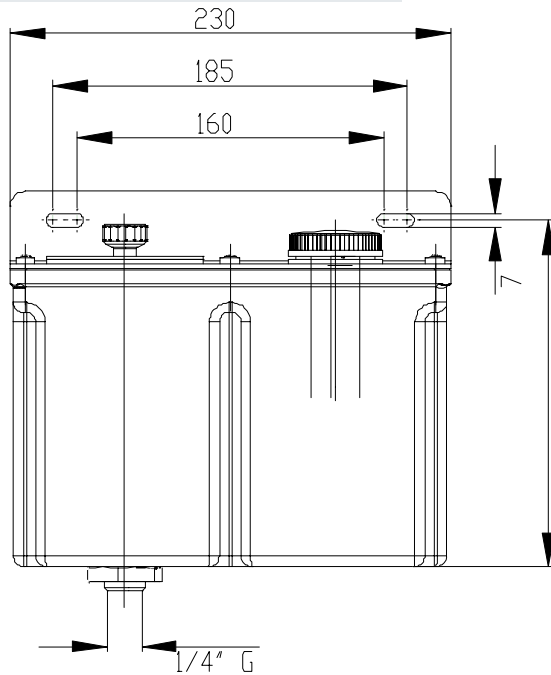
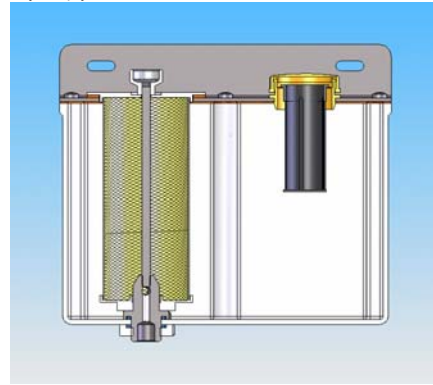
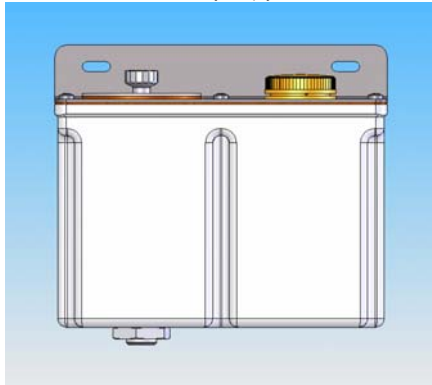

RACCORDI USCITA SERBATOIO		RESERVOIR OUTLET FITTINGS	
A92.106224	A92.106133	A92.106224	A92.106133
RACCORDO RAPIDO 1/4" A 90° TUBO DA 6 MM	RACCORDO RAPIDO 1/4" DIRITTO TUBO DA 6 MM	ELBOW PUSH-IN FITTING 1/4" TUBE 6 MM	STRAIGHT PUSH-IN FITTING 1/4" TUBE 6 MM

BVBA POMAC-LUB-SERVICES SPRL Pottestraat 23 B-8970 Poperinge
Tel. 057/33 48 36 – Fax 057/33 61 27 info@pomac.be – internet: www.pomac.be



LUBRIFICAZIONE AUTOMATICA DELLE CATENE AUTOMATIC CHAINS LUBRICATION

POMPA PS-R

LA PS-R E' UNA POMPA A PISTONI AZIONATA MECCANICAMENTE CON UNA CAMMA.

QUANDO IL PISTONE E' SOTTOPOSTO A PRESSIONE SI HA L'ASPIRAZIONE DAL SERBATOIO.

L'OLIO VA A RIEMPIRE LA CAMERA DI DOSAGGIO AL DI SOTTO DELLA MOLLA INTERNA ALLA POMPA.

TERMINATA LA PRESSIONE SUL PISTONE LA MOLLA HA LA POSSIBILITA' DI SPINGERE L'OLIO VERSO LA DISTRIBUZIONE.

UNA VOLTA CHE LA CONTROPRESSIONE EGUALIA LA PRESSIONE DELLA MOLLA SI RAGGIUNGE L'EQUILIBRIO E IL PISTONE TORNA INDIETRO ALLA VELOCITA' DEL CONSUMO DI OLIO.

IL SISTEMA CON LA PS-R MANTIENE IL LUBRIFICANTE A PRESSIONE COSTANTE NELLA LINEA PRINCIPALE E VA A REINTEGRARE QUESTA PRESSIONE QUANDO LE VALVOLE DOSATRICI CONSUMANO L'OLIO PER LUBRIFICARE I PUNTI.

IL SISTEMA PUO' ANCHE ESSERE UTILIZZATO COME UNO STRUMENTO A VOLUME COSTANTE IN APPLICAZIONI SENSIBILI AL CONSUMO DI LUBRIFICANTE. SI POSSONO UTILIZZARE VALVOLE DOSATRICI CON UNA MAGGIORE PORTATA PER ASSICURARSI CHE TUTTO L'OLIO DISPONIBILE VENGA CONSUMATO DURANTE IL FUNZIONAMENTO.

PER REGOLARE LE CORSE DEL PISTONE PUO' ESSERE FATTO UN CALCOLO ESATTO DEL CONSUMO DI LUBRIFICANTE AL FINE DI DARE I VOLUMI ESATTI AI PUNTI.

PS-R PUMP

PS-R KITS ARE SINGLE LINE OIL SYSTEMS THAT PRESSURISE A MAIN GALERY AND IS ROUTED THROUGH A SERIES OF MANIFOLDS. THE PRESSURE MADE AVAILABLE BY THE PUMP AND MAINTAINED BY IT'S SPRING, IS THEN ACCURATELY BLEED OUT THROUGH METERING VALVES TO THE VARIOUS POINTS REQUIRING LUBRICATION.

THE PS-R PUMP IS A DUAL VALVE PISTON PUMP, MECHANICALLY CHARGED, WITH SPRING INJECTION. THE CHARGE STROKE IS OPERATED BY CAM.

THE OIL IS DRAWN INTO THE BARREL UNDER VACUUM, AND SUFFICIENT TIME MUST BE ALLOWED FOR THIS ON HIGH VOLUME SYSTEMS. INJECTION IS BY THE PUMP'S OWN INTERNAL SPRING, AND ONCE THE BACK PRESSURE EQUALS THE SPRING PRESSURE, EQUILIBRIUM IS REACHED AND THE PISTON WILL ONLY RETURN AT THE RATE OF OIL CONSUMPTION.

PS-R SYSTEM THEREFORE BE USED AS A COSTANT PRESSURE DEVICE: CONSTANTLY TOPPING UP THE RING MAIN, BLEEDING OFF THE REQUIRED AMOUNT USING GRADUATE SIZES OF METER VALVE.

PS-R SYSTEM CAN ALSO BE USED AS A COSTANT VOLUME DEVICE IN APPLICATIONS WHICH ARE VERY SENSITIVE TO CONSUMPTION; MORE GENEROUS VALVES ARE FITTED ENSURING ALL THE AVAILABLE OIL IS USED BETWEEN OPERATIONS. AN EXACT CALCULATION OF CONSUMPTION CAN THEN BE MADE AND THE PUMP STROKE ADJUSTED TO GIVE THAT FRACTION OF SWEEP VOLUME REQUIRED PER OPERATION.

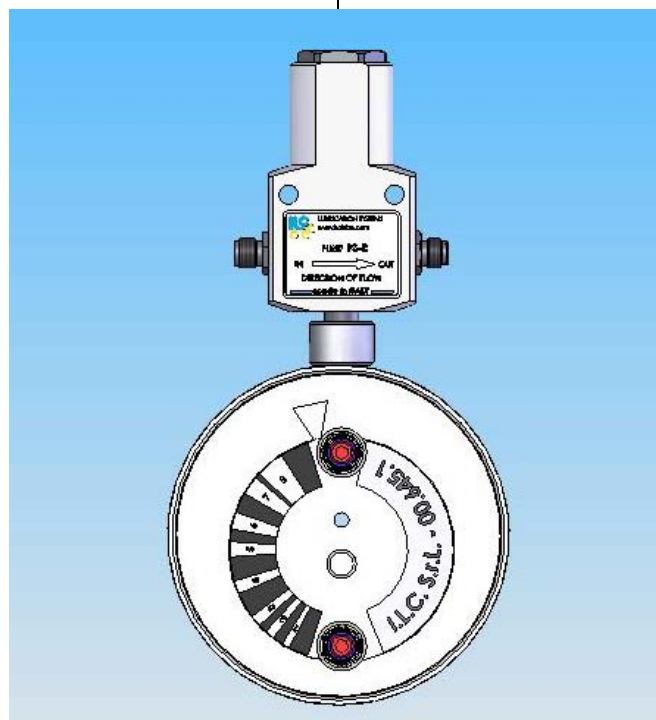

BVBA POMAC-LUB-SERVICES SPRL Pottestraat 23 B-8970 Poperinge
Tel. 057/33 48 36 – Fax 057/33 61 27 info@pomac.be – internet: www.pomac.be



LUBRIFICAZIONE AUTOMATICA DELLE CATENE AUTOMATIC CHAINS LUBRICATION

POMPA A PISTONE PS-R
CODICE 00.645.0

PISTON PUMP PS-R
CODE 00.645.0

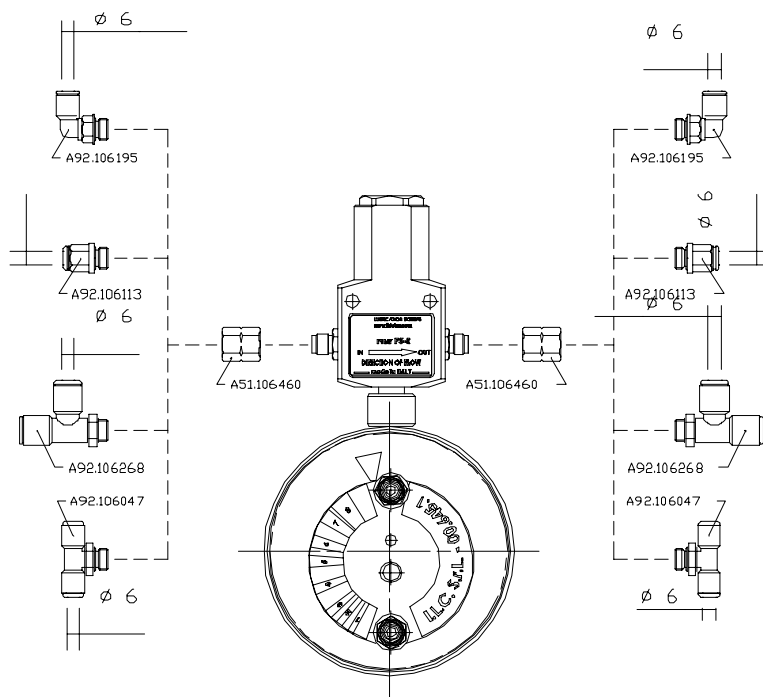
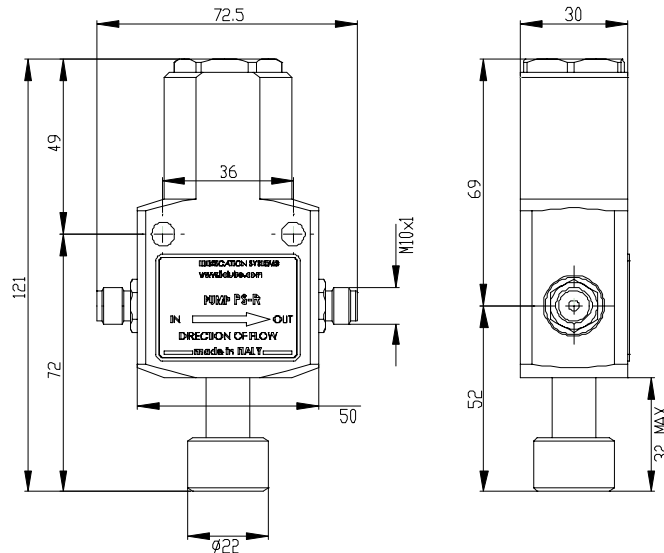

CARATTERISTICHE		FEATURES	
LUBRIFICANTI	OLII 50 -220 cSt 40 °C	LUBRICANTS	OIL 50 - 220 cSt 40 °C
PORTATA MASSIMA	2.2 CC / CORSA	MAXIMUM DISCHARGE	2.2 CC / STROKE
PRESSIONE MASSIMA	7 BAR	MAXIMUM PRESSURE	7 BAR
MASSIMA ALTEZZA ASPIRAZIONE	1 M	MAXIMUM HEIGHT FOR THE SUCTION	1 M
INGRESSO	TUBO 6 MM	INLET	6 MM HOSE
USCITA	TUBO 6 MM	OUTLET	6 MM HOSE
GIRI AL MINUTO MASSIMI	250	MAXIMUM RPM	250

BVBA POMAC-LUB-SERVICES SPRL Pottestraat 23 B-8970 Poperinge
Tel. 057/33 48 36 – Fax 057/33 61 27 info@pomac.be – internet: www.pomac.be



LUBRIFICAZIONE AUTOMATICA DELLE CATENE AUTOMATIC CHAINS LUBRICATION

CAMMA
CODICE 00.645.1

CAM
CODE 00.645.1

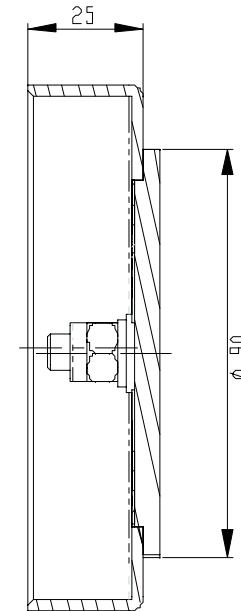
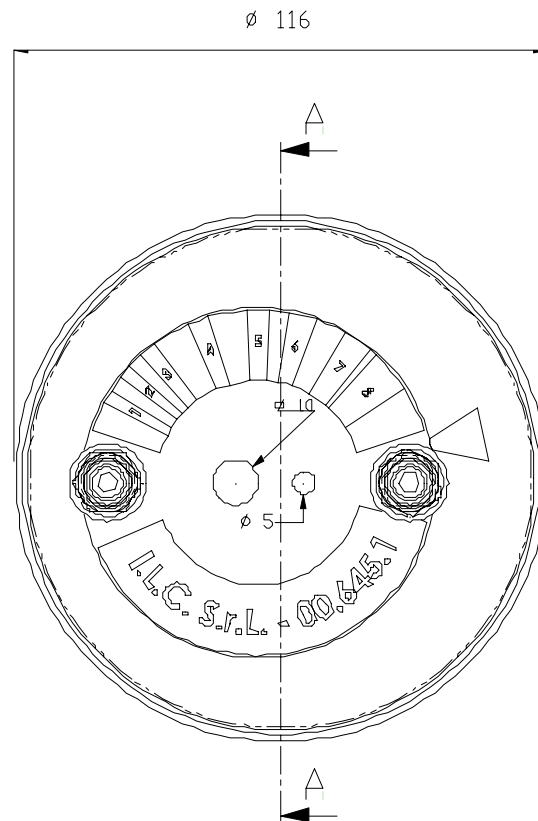

BVBA POMAC-LUB-SERVICES SPRL Pottestraat 23 B-8970 Poperinge
Tel. 057/33 48 36 – Fax 057/33 61 27 info@pomac.be – internet:www.pomac.be



LUBRIFICAZIONE AUTOMATICA DELLE CATENE AUTOMATIC CHAINS LUBRICATION

CAMMA + POMPA

CAM + PUMP

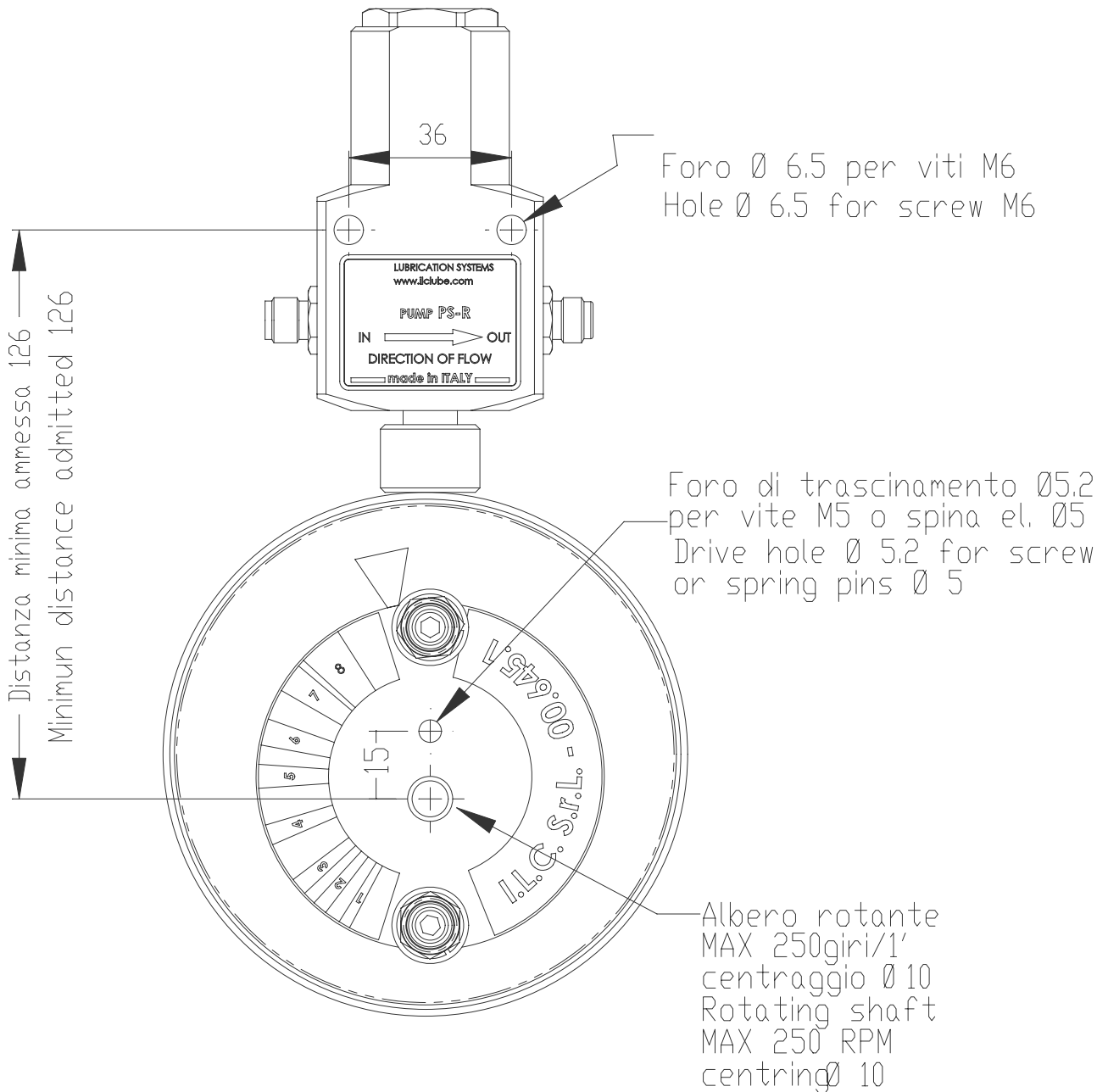

BVBA POMAC-LUB-SERVICES SPRL Pottestraat 23 B-8970 Poperinge
Tel. 057/33 48 36 – Fax 057/33 61 27 info@pomac.be – internet: www.pomac.be



LUBRIFICAZIONE AUTOMATICA DELLE CATENE AUTOMATIC CHAINS LUBRICATION

DISTRIBUTORI

MANIFOLD

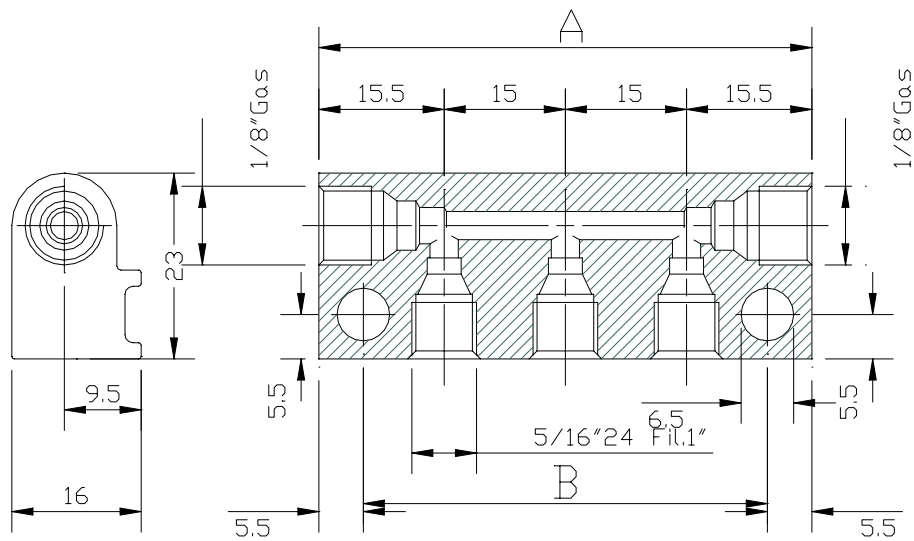

CODICE CODE	USCITE OTLETS	A	B
01.030.1	1	20	31
01.040.1	2	35	46
01.050.1	3	50	61
01.060.1	4	65	76
01.070.1	5	80	91
01.080.1	6	95	106
01.090.1	7	110	121
01.100.1	8	125	136
01.110.0	9	140	151
01.120.1	10	155	166

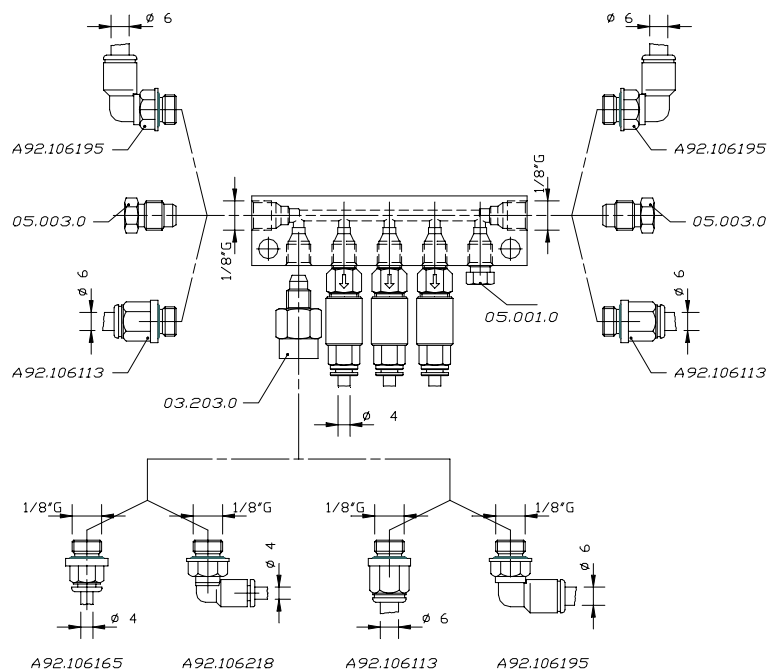

BVBA POMAC-LUB-SERVICES SPRL Pottestraat 23 B-8970 Poperinge
Tel. 057/33 48 36 – Fax 057/33 61 27 info@pomac.be – internet: www.pomac.be



LUBRIFICAZIONE AUTOMATICA DELLE CATENE AUTOMATIC CHAINS LUBRICATION

VALVOLE DOSATRICI COMPLETE DI RACCORDO RAPIDO PER TUBO 4 MM

LE VALVOLE DOSATRICI SONO DISPONIBILI CON VARIE PORTATE PER ADATTARSI ALLA RICHIESTA DEI PUNTI DI LUBRIFICAZIONE.

CONTENGONO UN PICCOLO FILTRO, UN ELICA E UNA VALVOLA DI NON RITORNO.

IL FILTRO ELIMINA LE PARTICELLE CHE POSSONO ENTRARE DURANTE L'ASSEMBLAGGIO. LA PROFONDITA' DELL'ELICA DETERMINA LA PORTATA E ASSICURA CHE, QUALUNQUE SIA LA CONTROPRESSIONE DEL CUSCINETTO, NON DARA' PIU' OLIO DI QUELLO RICHIESTO.

ALTRI PUNTI NON SONO INFLUENZATI DA ROTTURE O BLOCCAGGI DELLE TUBAZIONI SECONDARIE.

PREVENGONO LO SVUOTAMENTO DELLE TUBAZIONI DURANTI I PERIODI DI FERMO MACCHINA.

APRONO AD UNA PRESSIONE DI 5 PSI (0.35 BAR) E 10 PSI (0.69) BAR

METERING VALVES COMPLETE OF PUSH-IN FITTING FOR 4 MM HOSE

METERING VALVES ARE AVAILABLE IN A RANGE OF SIZES TO CONTROL THE FLOW RATE. THEY ALLOW A RATIO OF FEEDS TO VARIOUS LUBRICATION POINTS.

THE VALVE CONTAINS A SMALL FILTER, A GROUND HELICAL PLUG AND A NON-RETURN VALVE. THE FILTER ELIMINATES PARTICLES WHICH MAY ENTER DURING ASSEMBLY. THE DEPTH OF THE HELIX GOVERNS THE FLOW OF OIL THROUGH THE DEVICE AND ENSURES THAT WHATEVER THE BACK PRESSURE OF THE BEARING, IT WILL NEVER DRAW MORE OIL THAN REQUIRED.

THIS ENSURES THAT OTHER POINTS ARE NOT AFFECTED BY BROKEN OR BLOCKED SECONDARY PIPES. THE VALVE PREVENTS OIL SYPHONING OUT OF THE MAIN GALLERY AND SECONDARY PIPEWORK DURING PERIODS WHEN THE MACHINE IS NOT WORKING.

THE VALVE OPEN BETWEEN 5 PSI (0.35 BAR) AND 10 PSI (0.69 BAR)

5/16" 24 Fil.1"

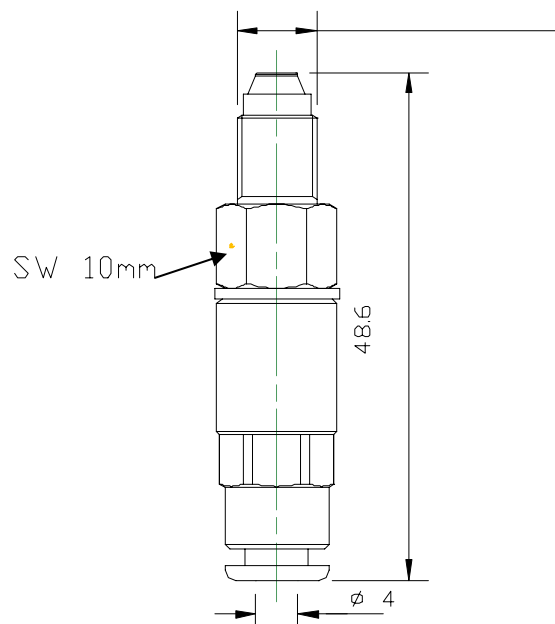

CODICE CODE	DOSAGGIO CC/MINUTO (DA - A) METERED QUANTITY CC/MINUTE (FROM - TO)	TIPO TYPE	TIPO TYPE
02.006.0	0.085 - 0.115	0	IM20
02.006.1	0.170 - 0.230	1	IM21
02.006.2	0.340 - 0.460	2	IM22
02.006.3	0.680 - 0.920	3	IM23
02.006.4	1.360 - 1.840	4	IM24
02.006.5	2.720 - 3.680	5	IM25
02.006.6	5.440 - 7.360	6	IM26
02.006.7	10.880 - 14.720	7	IM27
02.006.8	21.760 - 29.440	8	IM28
02.006.9	43.520 - 58.880	9	IM29

BVBA POMAC-LUB-SERVICES SPRL Pottestraat 23 B-8970 Poperinge
Tel. 057/33 48 36 – Fax 057/33 61 27 info@pomac.be – internet: www.pomac.be



LUBRIFICAZIONE AUTOMATICA DELLE CATENE AUTOMATIC CHAINS LUBRICATION

SPAZZOLE

BRUSHES

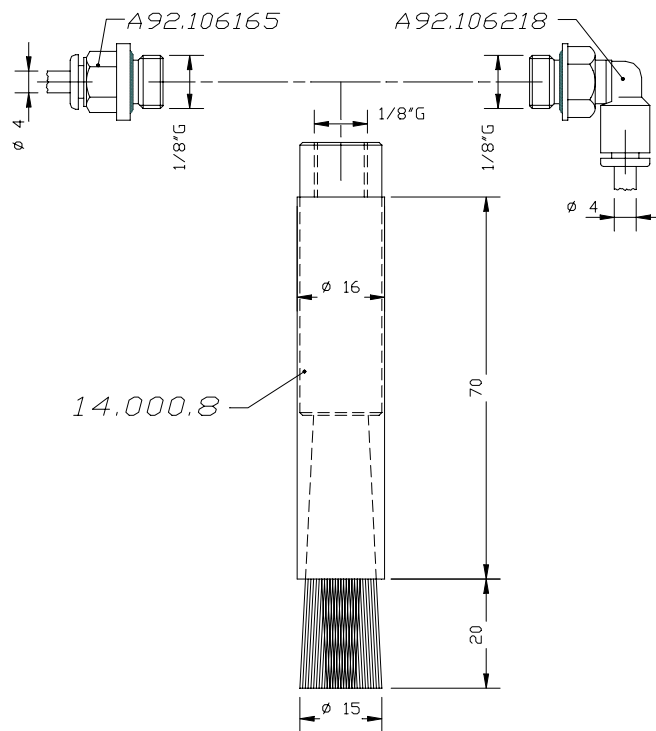

FISSASPAZZOLA CON PROTEZIONE IN GOMMA
08.608.5

CLAMPS WITH RUBBER PROTECTION
08.608.5

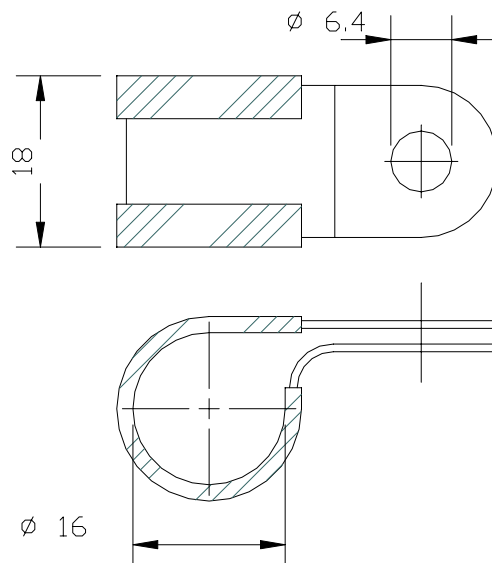

BVBA POMAC-LUB-SERVICES SPRL Pottestraat 23 B-8970 Poperinge
Tel. 057/33 48 36 – Fax 057/33 61 27 info@pomac.be – internet: www.pomac.be



LUBRIFICAZIONE AUTOMATICA DELLE CATENE AUTOMATIC CHAINS LUBRICATION

SPAZZOLE

BRUSHES

14.000.1

14.000.2

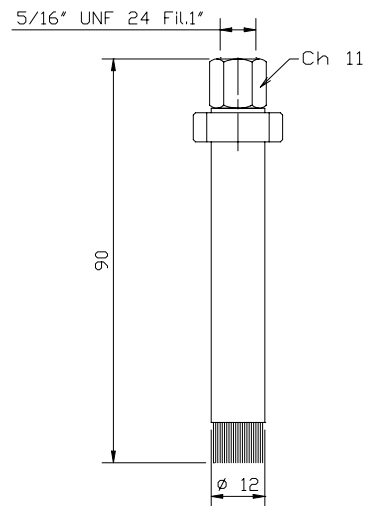
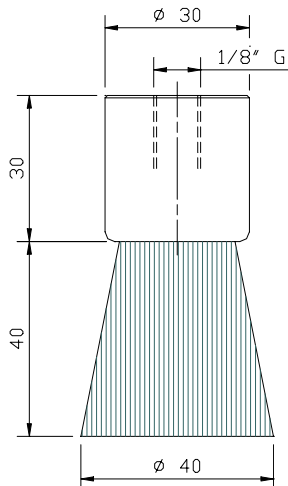

14.000.3

14.000.4

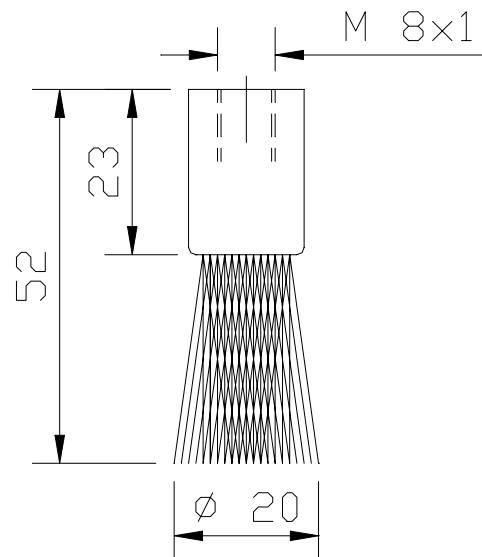
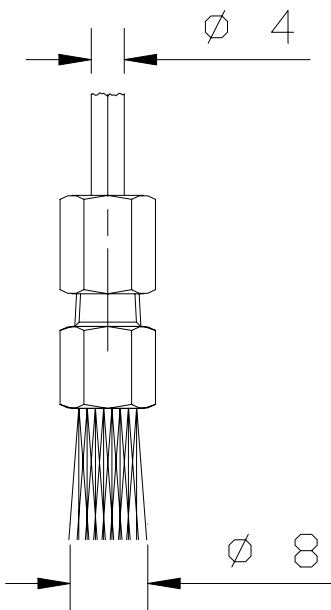

BVBA POMAC-LUB-SERVICES SPRL Pottestraat 23 B-8970 Poperinge
Tel. 057/33 48 36 – Fax 057/33 61 27 info@pomac.be – internet: www.pomac.be